



PSIRP
PUBLISH-SUBSCRIBE
INTERNET ROUTING
PARADIGM

**Concrete results already available,
with evidence that it could work**



PSIRP
PUBLISH-SUBSCRIBE
INTERNET ROUTING
PARADIGM

Future Internet Assembly, Valencia, Spain, 2010-04-15
Dr. Arto Karila, Helsinki Institute for Information Technology

Concrete results of PSIRP

- Complete scalable entirely pub/sub-based architecture with security and mobility designed in
- zFilter (Bloom filter) based inter-domain multicast
- Working prototypes of the core components
- Some test applications
- The architecture fits well onto existing link layers, such as Ethernet and GMPLS

RTFM architecture

- Rendezvous - matching publish and subscribe events
- Topology - network topology knowledge, path creation
- Forwarding - fast delivery

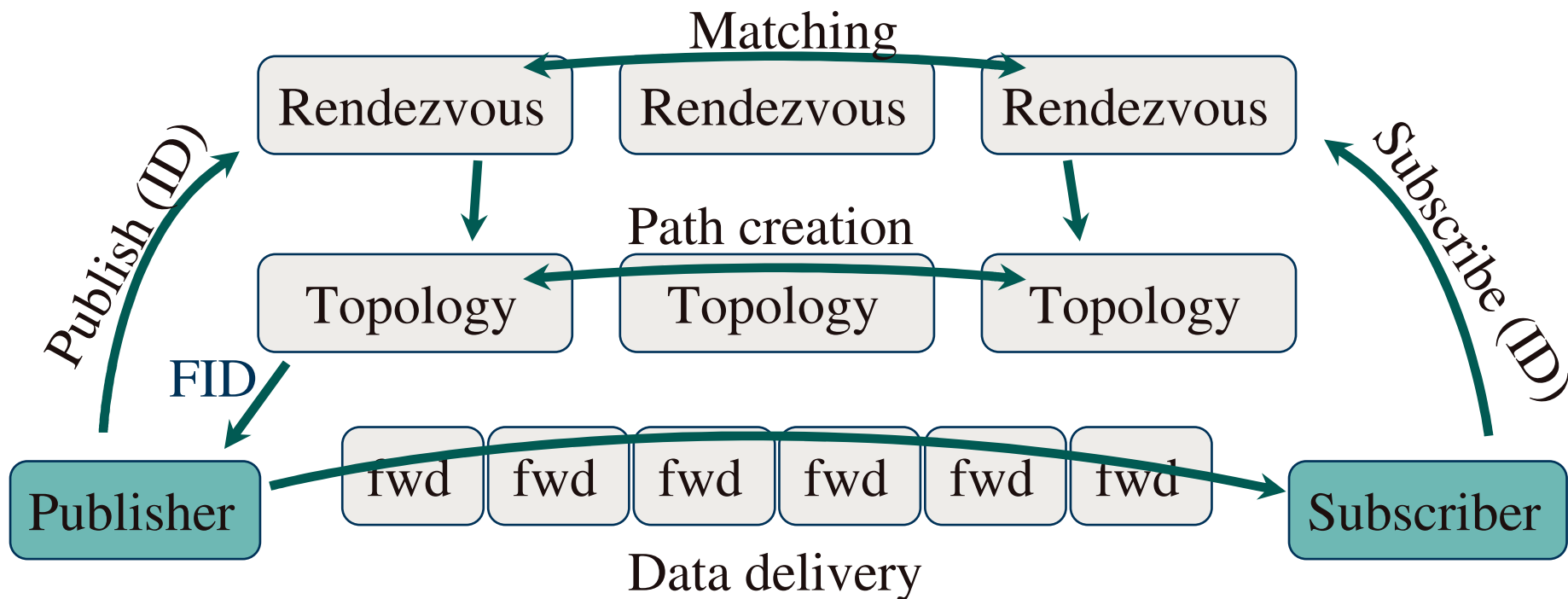



Evidence that it could work

- An open-source implementation of the core architecture:
 - FreeBSD-based **BlackHawk** prototype (end node)
 - **NetFPGA** based forwarding
 - Working **rendezvous server**
- Some test applications, including:
 - **Multicast BitTorrent**
 - **Firefox plug-in**
 - **Socket emulator**
- All of the components above are already working but the integration is still not complete
- An integrated system, including some applications, will be demonstrated at ICT 2010 in Brussels in September

Implementation

- NS3 simulator
- FreeBSD 7.x : end-host + forwarding
- NetFPGA : Forwarding
- BSD & NetFPGA Implementations available at <http://www.psirp.org>

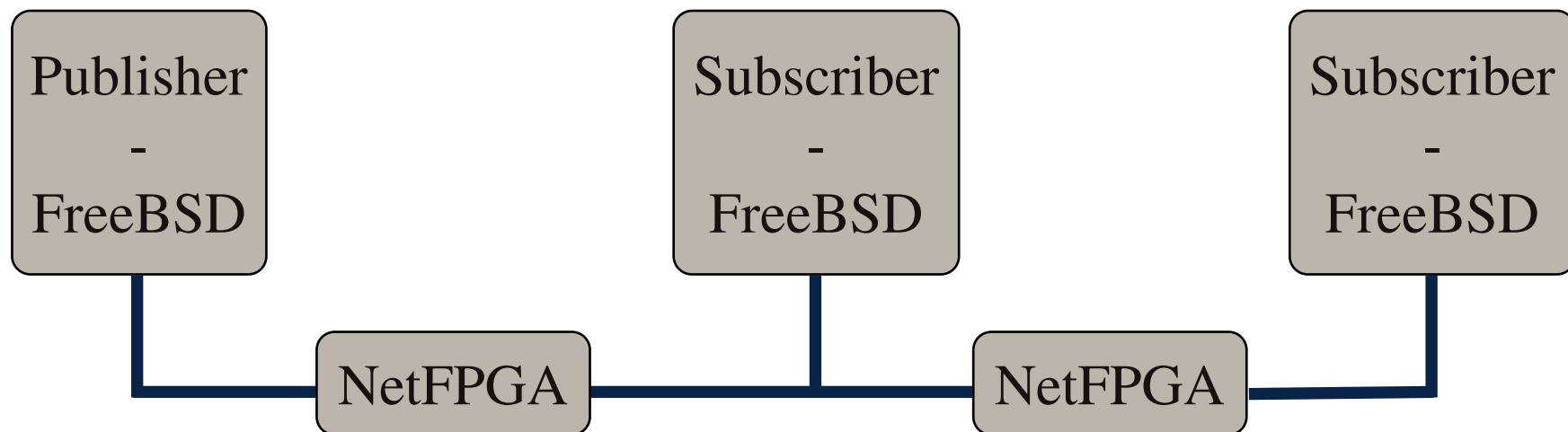

- The PSIRP implementation is validated on a relatively large and real-life-like testbed
- The University of Cambridge and the University of Essex are testing PSIRP over an optical connection between them
- VPN connections will be created to other partners (including Aachen, Athens, Helsinki and Sofia)
- PSIRP is cooperating with OneLab2 under FIRE
- The University of Essex is integrating the Blackhawk with campus-wide wireless network (using a dedicated SSID) accessible to 2500+ students in their dorms
- Helsinki University of Technology is running a code camp where students develop applications on the BlackHawk
- Interested parties are invited to join in the testbed – the hardware is inexpensive and the software is downloadable at <http://www.psirp.org>



Bloom filters – basic idea

Inserting items
Hash and set bits

Verifying
Hash and check if set

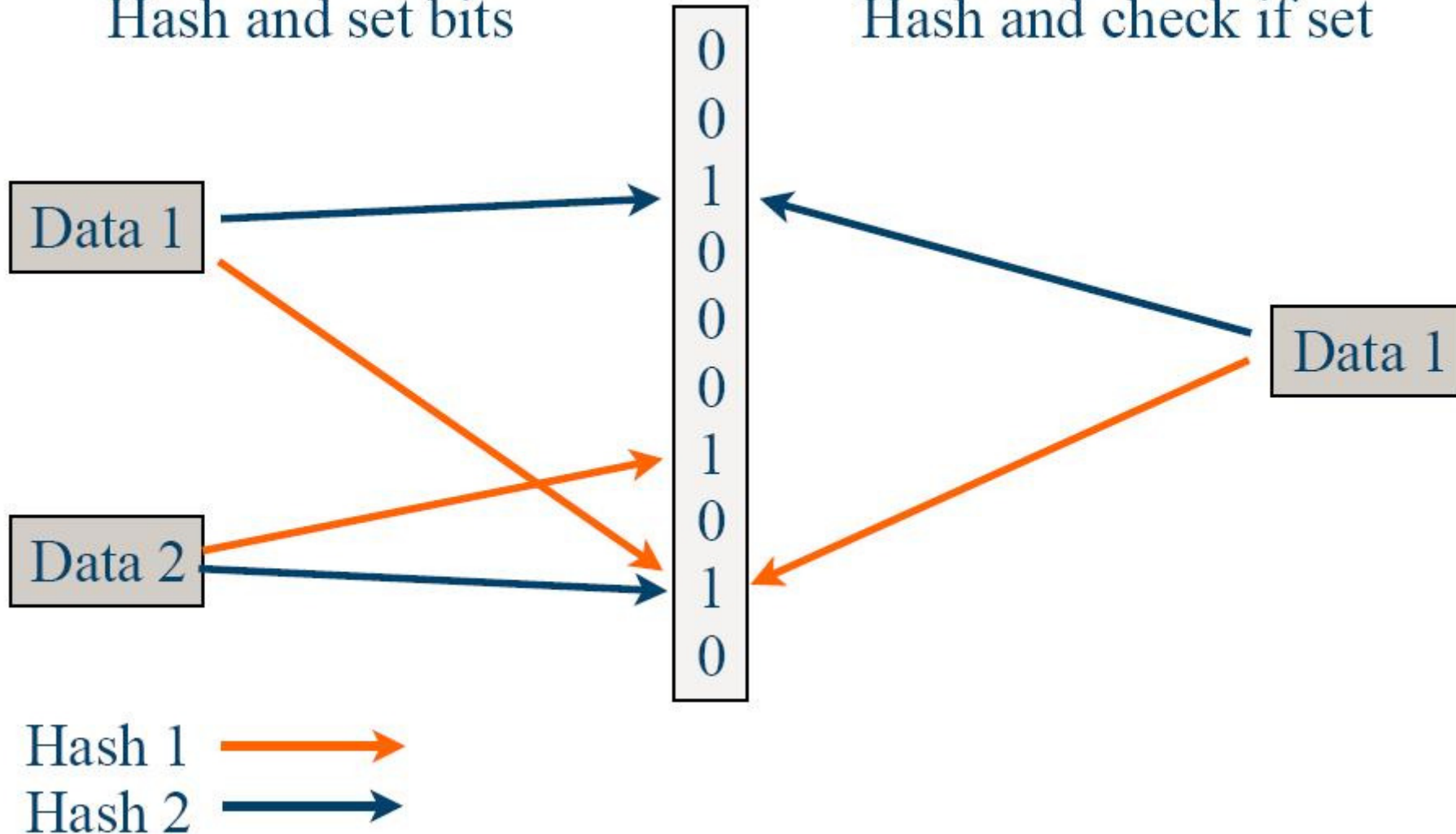

Link IDs and forwarding Bloom filters (zFilters)

- No names for nodes
 - Each *link* is identified with a unidirectional Link ID
- Link IDs
 - Statistically unique
 - Periodically changing
 - Size e.g. 256 bits
 - Local or centrally controlled
- Source routing
 - Include all Link IDs into a Bloom filter
 - Multicasting supported
- “Stateless”

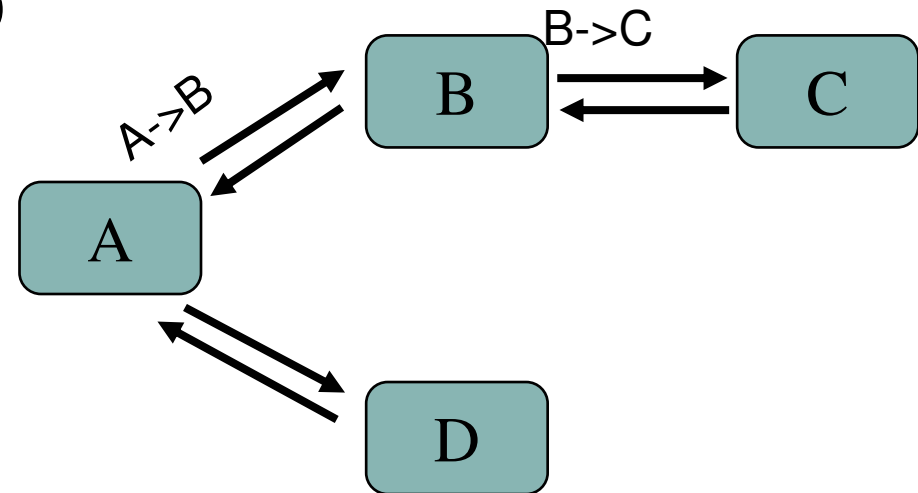

A->B	0	1	0	0	0	1	0	0	1
B->C	1	0	0	0	0	1	1	0	0
zF: A->B->C	1	1	0	0	0	1	1	0	1

Forwarding Decision

Forwarding decision based on binary AND and CMP

- zFilter in the packet matched with all outgoing Link IDs
- Multicasting: zFilter contains more than one outgoing links

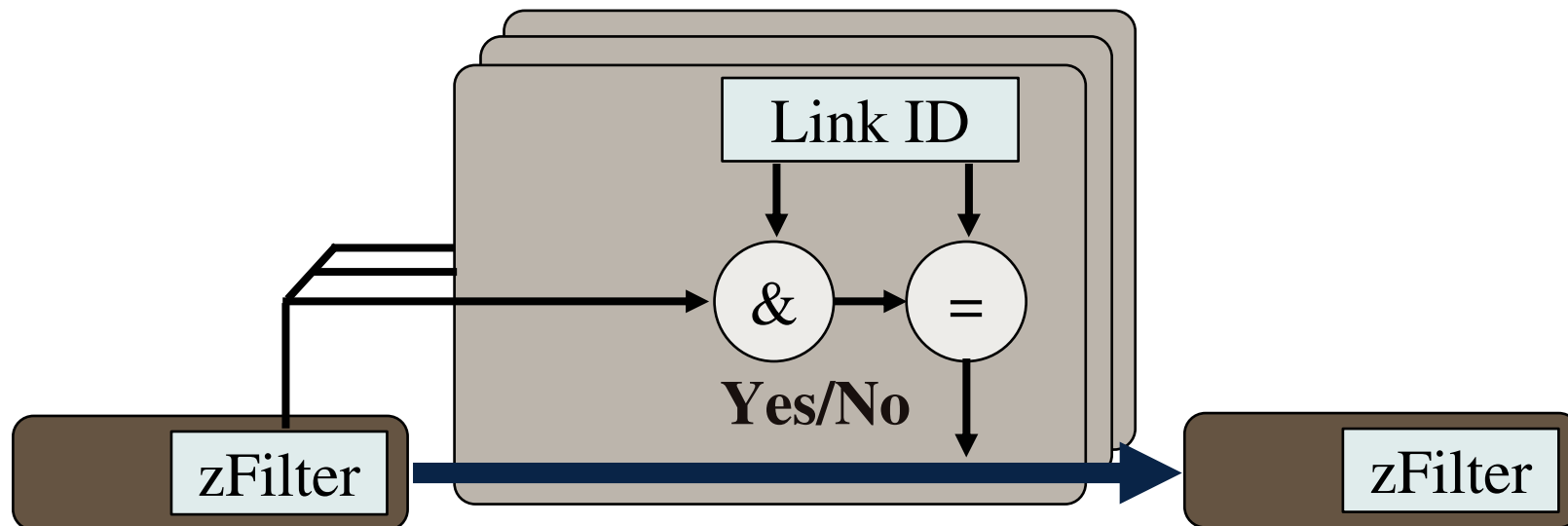

Using Link Identity Tags (LIT)

- Make results better with a simple trick
 - Define d different LITs instead of a single LID
 - LIT has the same size as LID, and also k bits set to 1
 - [Power of choices]
- Route creation and packet forwarding
 - Calculate d different candidate zFilters
 - Select the best performing zFilter, based on some policy

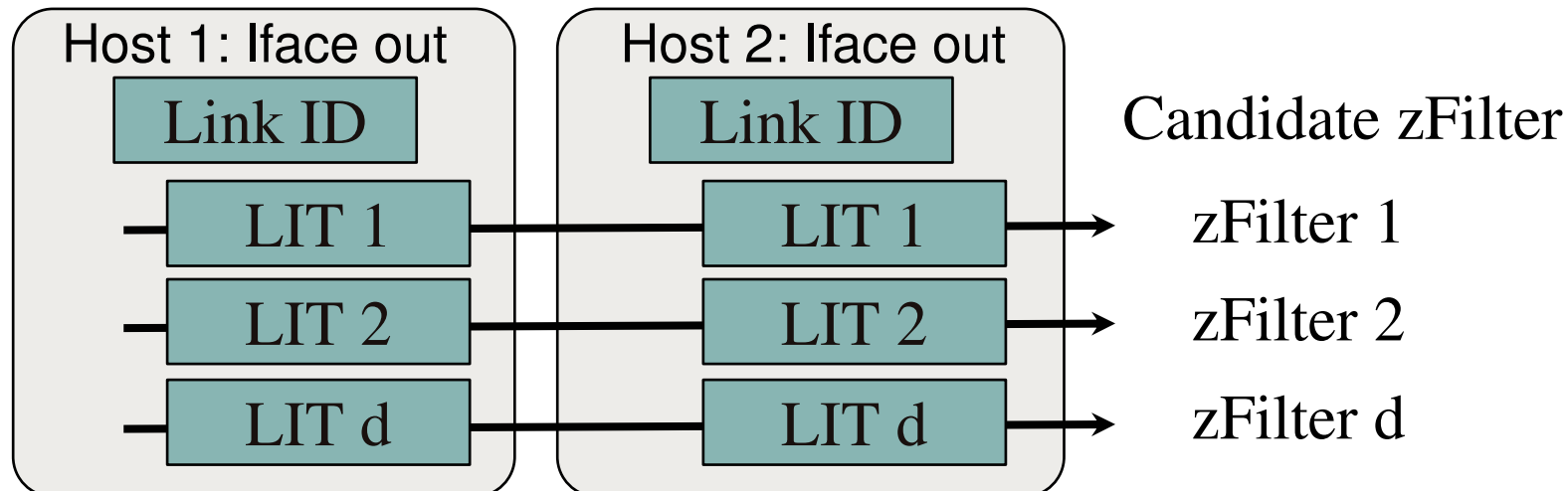



Using Link Identity Tags (LIT)

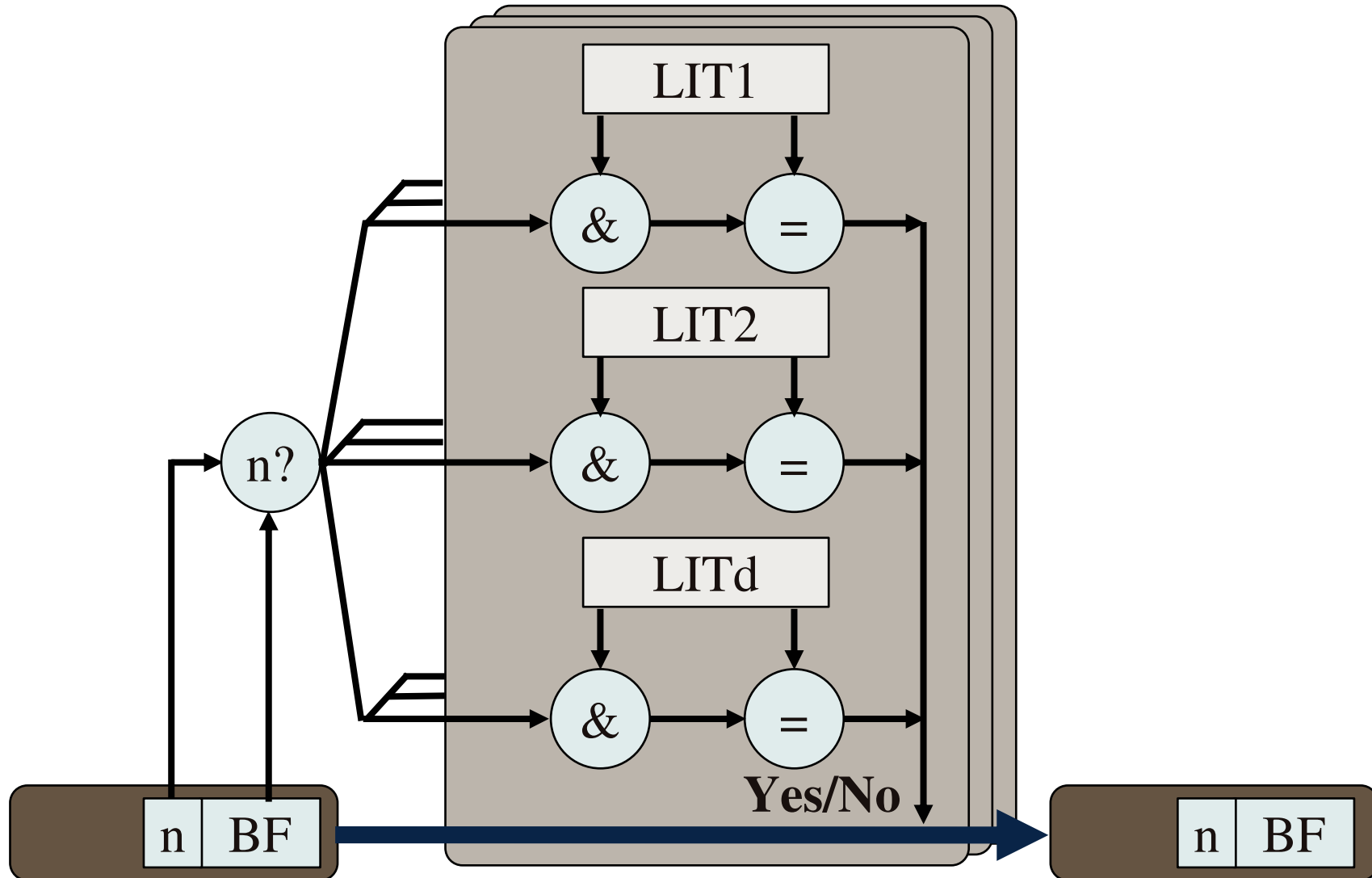

Forwarding efficiency

- Simulations with
 - Rocketfuel
 - SNDlib
- Forwarding efficiency with 20 subscribers
 - ~80%

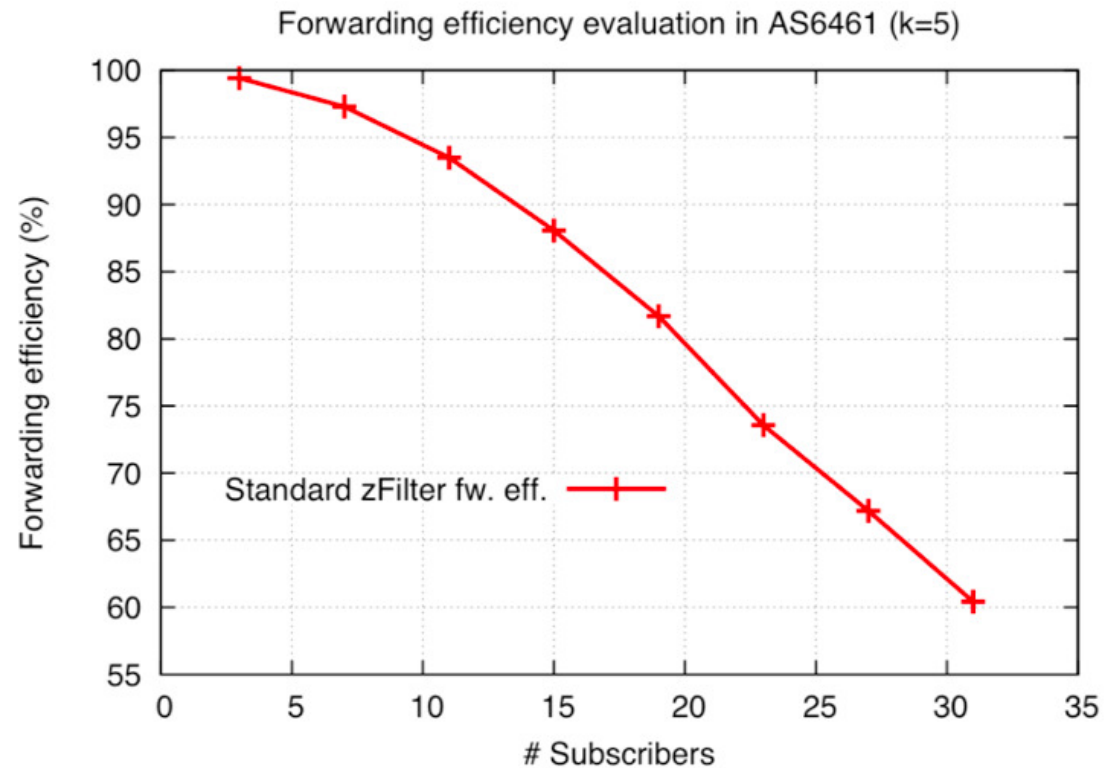

Forwarding efficiency

- Simulations with
 - Rocketfuel
 - SNDlib
- Forwarding efficiency with 20 subscribers
 - ~80%
 - LIT optimized: 88%

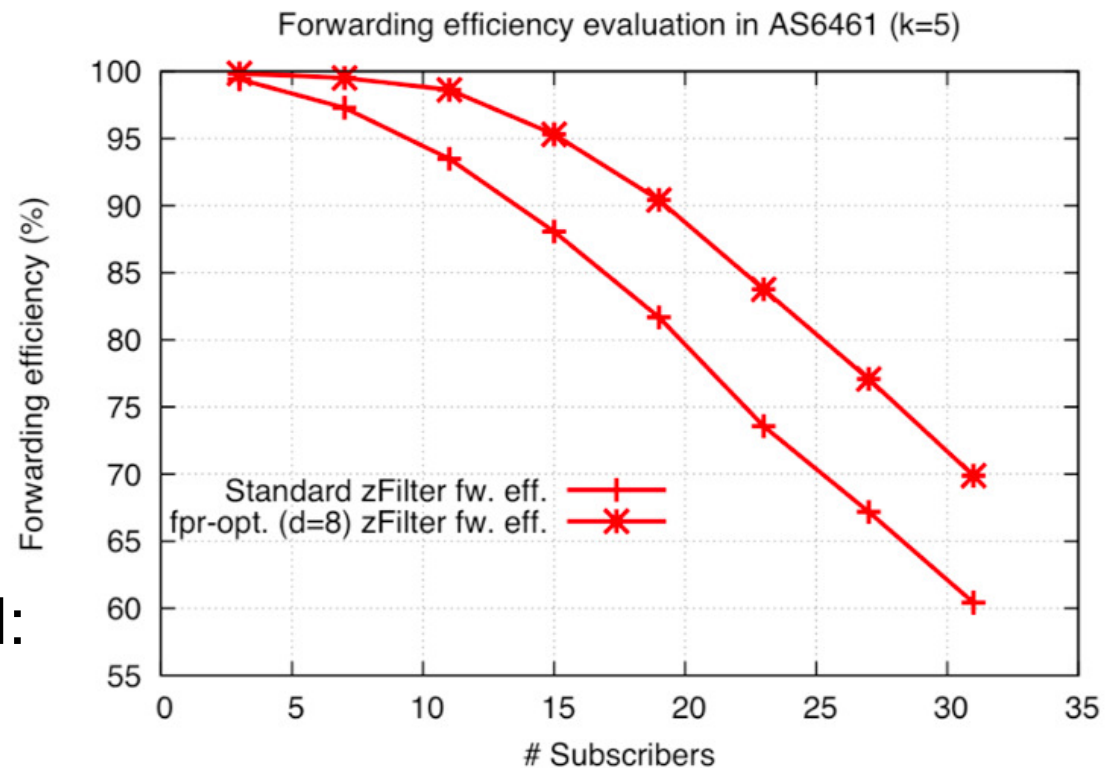

Virtual Trees

- Popular paths can be merged into virtual trees
 - A single Link ID for the tree
 - Additional state in the forwarding nodes
 - Increase scalability

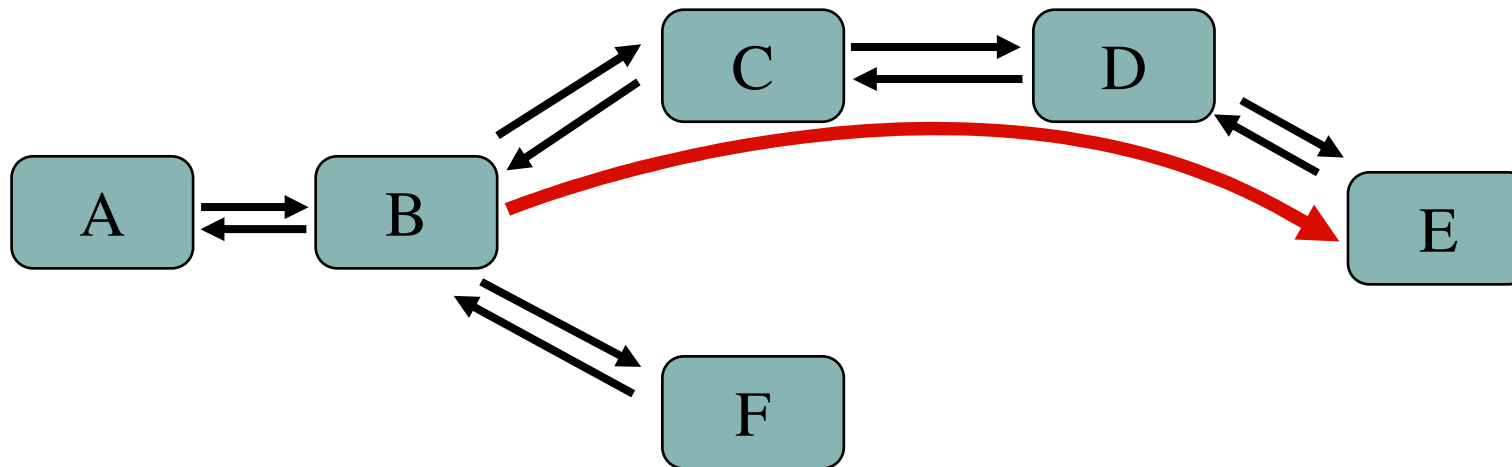

Virtual B->C->D->E 0 0 1 0 1 0 0 0 1

Summary of LIPSIN and zFilters

- Link-identity-based source routing
- Stateless small-group multicast and unicast
- Small forwarding table
- Very simple forwarding decision
- Preventing unwanted traffic
 - No possibility to send data by guessing the destination
- Forwarding implemented in both software and hardware



PSIRP
PUBLISH-SUBSCRIBE
INTERNET ROUTING
PARADIGM



PSIRP

PUBLISH-SUBSCRIBE
INTERNET ROUTING
PARADIGM